

INSTALLATION GUIDE-PENDANT

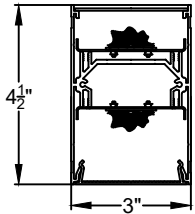

Risk of fire and electrical shock. In accordance with national local building and electrical codes, CORONET lighting fixtures must be installed by a qualified electrician. Disconnect power at electrical panel before servicing.

CROSS SECTION VIEW



SIDE VIEW

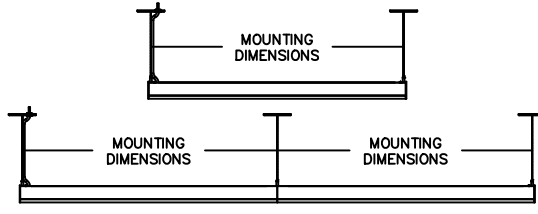

PLEASE CONSULT FACTORY SHOP DRAWINGS FOR SUSPENSION POINTS

PART LIST

- | | |
|-------------------|---------------------------------|
| A-End Plate | K-Female Connecting Bracket |
| B-Bottom LED Tray | L-8-32 Screw |
| C-Male Gripper | M-Center Bottom Support Bracket |
| D-Extrusion | N-8-32 Nut |
| E-Power Cable | P-Center Top Support Bracket |
| F-Bottom Lens | Q-Male Gripper |
| G-Top Lens | R-Flat Head Screw |
| H-Top LED Tray | S-Male Connecting Bracket |
| J-Bushing | T-Alignment Pin |
| | U-Light Shield Plate |

EXPLODED CONNECTION DETAIL

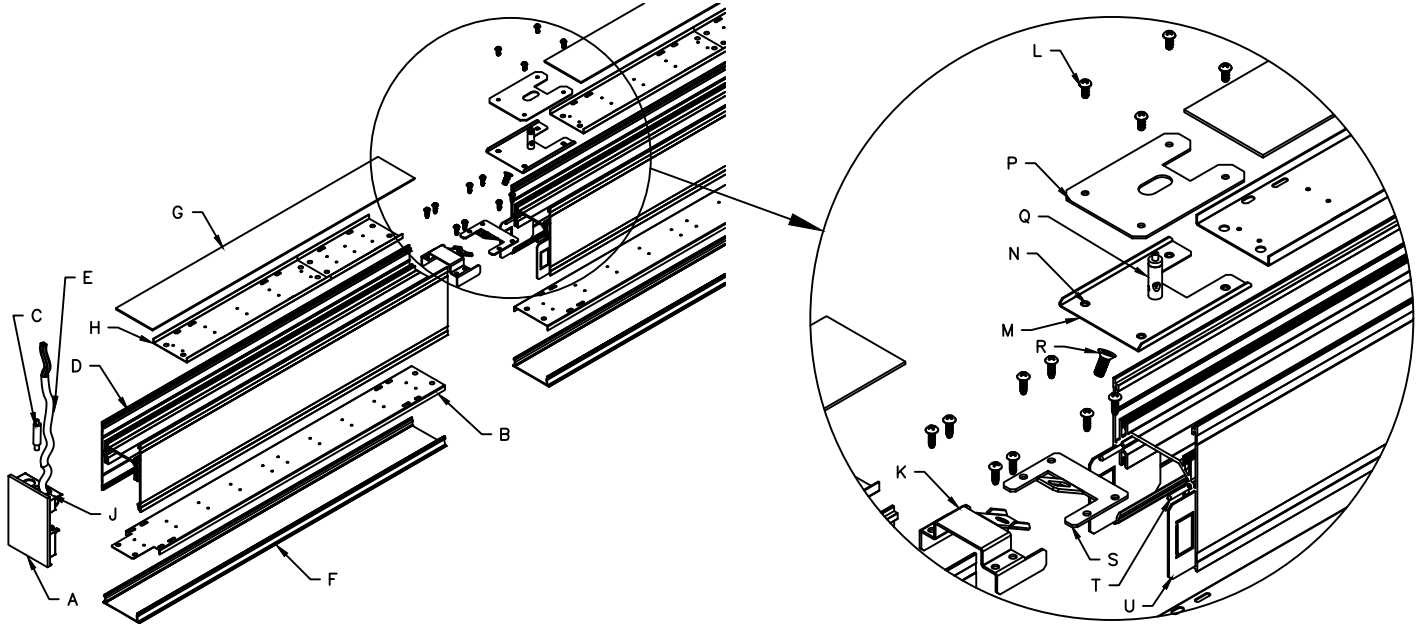

EXPLODED VIEWS ARE TO SHOW DETAIL ONLY, FIXTURES ARE SHIPPED PRE-ASSEMBLED.

FEED DETAIL

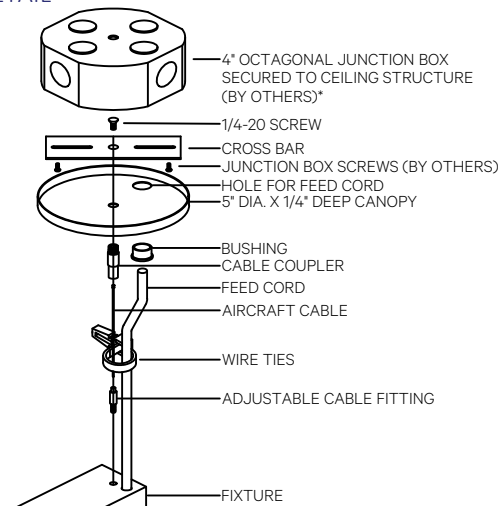

NON FEED DETAIL

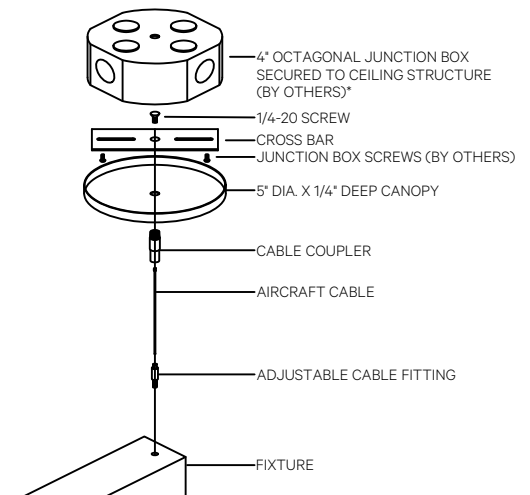

*NOTE: JUNCTION BOXES MUST BE SOLIDLY FIXED TO THE CEILING AND ATTACHED TO THE STRUCTURAL MEMBER INSIDE THE CEILING BEFORE PROCEEDING WITH INSTALLATION.

INSTALLATION GUIDE-PENDANT



Risk of fire and electrical shock. In accordance with national local building and electrical codes, CORONET lighting fixtures must be installed by a qualified electrician. Disconnect power at electrical panel before servicing.

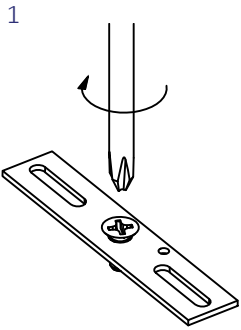

1
Screw the provided 1/4-20 hanging screw before attaching the cross bar to the junction box.

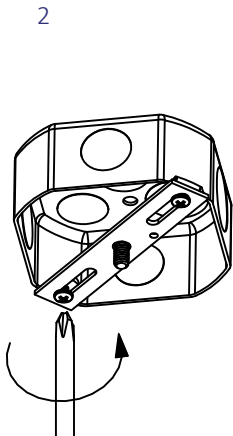

2
Secure the cross bar to the octagonal junction box with the junction box screws.

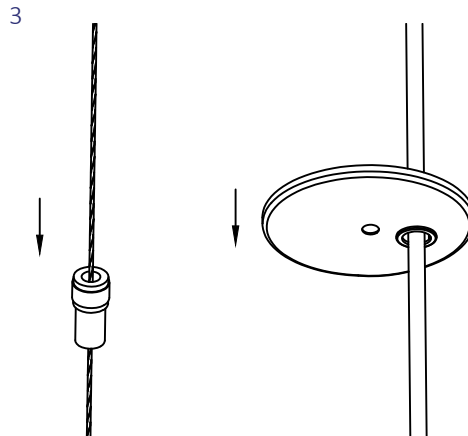

3
Run the aircraft cable through the cable coupler and the power feed cable through the canopy respectively.

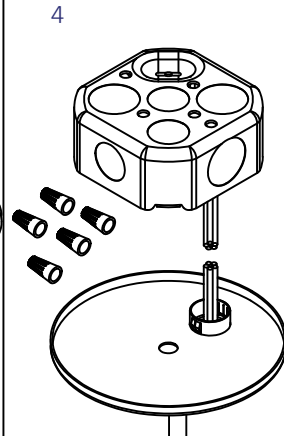

4
With the power to the fixture circuit off, connect the fixture power cord to the power feed in the junction box. (Wire connectors by others)

GREEN-GROUND
WHITE-NEUTRAL
BLACK-LINE
GRAY-0-10V DIMMABLE
PURPLE-0-10 V DIMMABLE

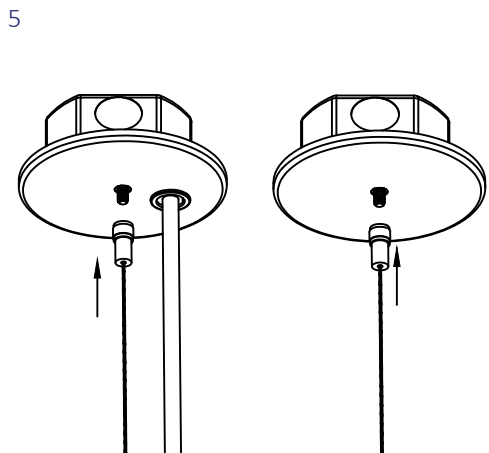

5
Using the 1/4-20 cross bar screw, position the canopy and secure in place with the cable coupler.

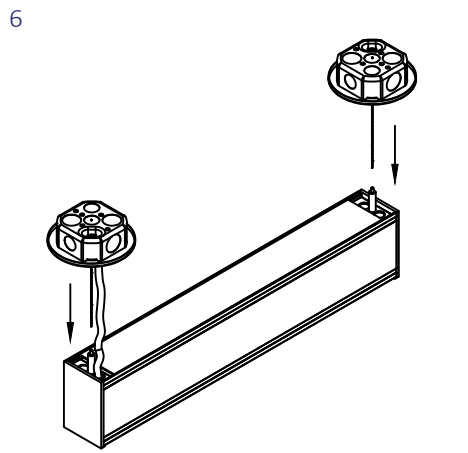

6
Insert the aircraft cable into the cable grippers on both sides of the fixture

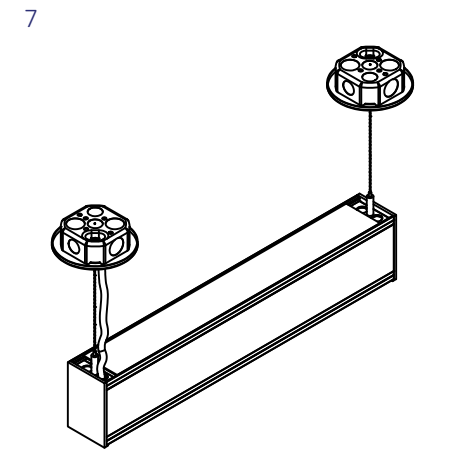

7
Adjust the aircraft cables until the desired height is achieved.
Note: Fixture must be level.

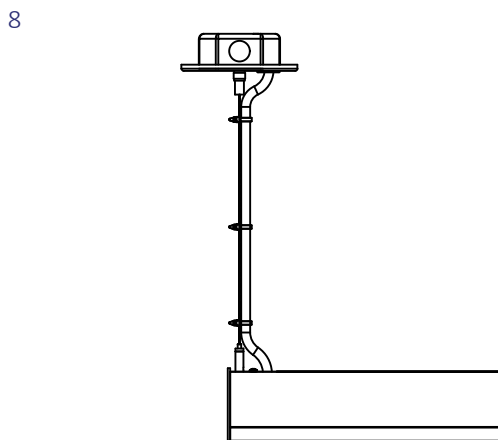

8
Secure power cord to aircraft cable using plastic cable ties.

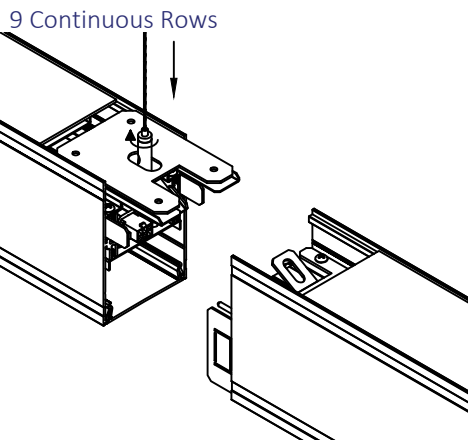

9 Continuous Rows
Screw on the male cable gripper to the middle support bracket.

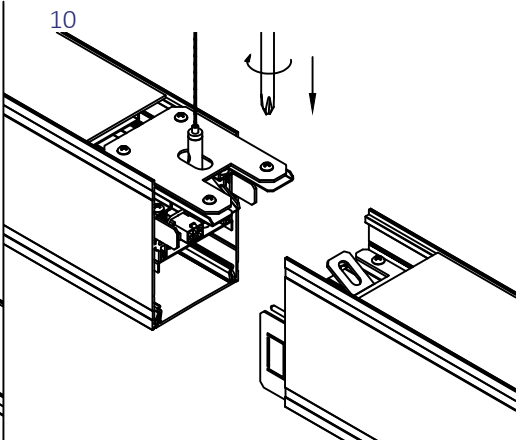

10
Tighten the screws to connect the two middle brackets together.

NOTE: JUNCTION BOXES MUST BE SOLIDLY FIXED TO THE CEILING AND ATTACHED TO THE STRUCTURAL MEMBER INSIDE THE CEILING BEFORE PROCEEDING WITH INSTALLATION.

INSTALLATION GUIDE-PENDANT



Risk of fire and electrical shock. In accordance with national local building and electrical codes, CORONET lighting fixtures must be installed by a qualified electrician. Disconnect power at electrical panel before servicing.

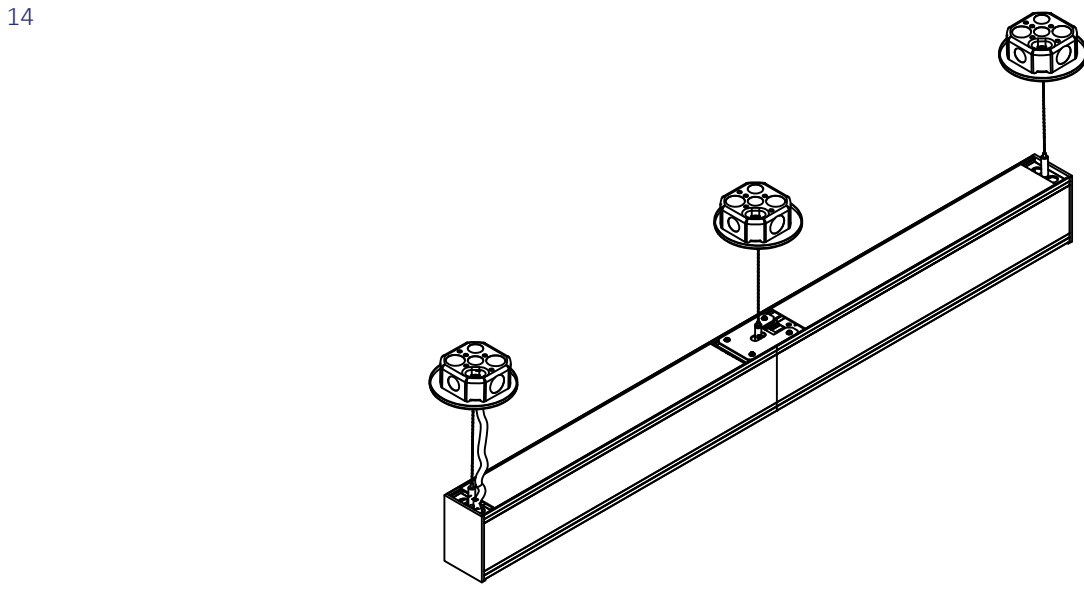
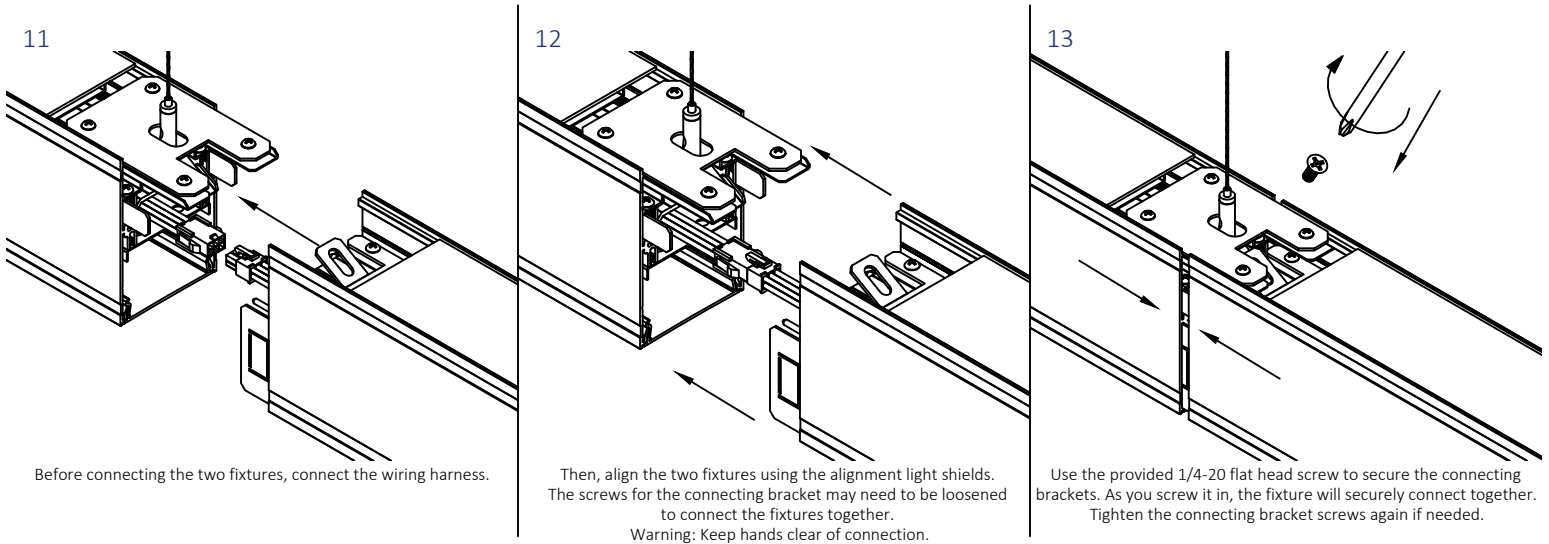

Fixture must be hung level at the desired height. If fixture is not level, light leaks may occur at the seam.

GENERAL INSTALLATION CONSIDERATIONS - See submittal drawings for job specific data.

Operating Temperature.....	-40°C to 50°C
Operating Voltage.....	110VAC-277VAC, 50Hz-60Hz
Weight.....	.2.8 lb/ft
Dimensions.....	See submittal drawings

- Installation by a certified electrician only.
- Read and understand the installation instructions before attempting to install or use the fixture.
- Only use fixtures with voltage for which it is rated. Do not exceed the specified voltage and current input.
- Do not use the fixture if the housing, lens, or power cable is damaged.
- Ensure that the main power supply is off before installing or wiring the fixture.
- Method of wire connection to be determined by local electrical codes and regulations.
- The external flexible cable of this luminaire cannot be field replaced; if the cord is damaged, contact Coronet.
- The light source contained in this luminaire shall only be replaced by the lighting manufacturer or his service agent or a similar qualified person.

Please contact our technical support team for assistance.

NOTE: JUNCTION BOXES MUST BE SOLIDLY FIXED TO THE CEILING AND ATTACHED TO THE STRUCTURAL MEMBER INSIDE THE CEILING BEFORE PROCEEDING WITH INSTALLATION.